

450 Series

ARTICULATING BOOM LIFT
SEMI-TRACK OPTION PACKAGE



Exclusive JLG
Floating Idler System



Removable Tracks
for Versatility



Greater Terrainability

450A
450AJ



JLG MODEL 450/SEMI-TRACK

PERFORMANCE FEATURES

Semi-Track Major Advantages

With JLG's exciting new Semi-Track Option Package you can start earning additional rental income immediately by keeping more of your JLG equipment on the move year round. Now available for JLG models 450A and 450AJ articulating boom lifts, the Semi-Track option provides maximum terrainability on the toughest job sites, keeping equipment moving even on tough terrain or steep grades. During inclement weather, the Semi-Track stays on the job, providing you with a higher return on investment. Plus, for added versatility the machine can be converted back to a wheeled machine by simply removing a few bolts.

Greater Terrainability with Steel Track

The Semi-Track option helps get you where you need to go, thanks to improved traction provided by a bolt-on steel track. It handles demanding conditions such as rough terrain (mud, rocks, etc.) and inclement weather (snow, rain, etc.).

Exclusive Floating Idler System

This unique JLG design allows the drive wheels to remain in contact with the ground for improved traction on uneven surfaces.

Removable Tracks

Adds unparalleled versatility to your rental fleet.

The JLG "1 & 5" Warranty

JLG Industries, Inc. backs our products with our exclusive "1 & 5" Warranty. We provide coverage on all products for one (1) full year, and cover all specified major structural components for five (5) full years. Due to continuous product improvements, we reserve the right to make specification and/or equipment changes without prior notification. These machines meet or exceed applicable OSHA Regulations in 29 CFR 1910.67, 29 CFR 1926.453 and ANSI A92.5-1992 as originally manufactured for intended applications.

The JLG Promise

Whether you rent or own a JLG lift, you can expect the best in terms of safety, reliability, productivity and ease of use for the operator.

JLG Industries, Inc.

1 JLG Drive
 McConnellsburg, PA 17233-9553
 Telephone 717-485-5161
 Toll-free in US 877-JLG-LIFT
 Fax 717-485-6417
www.jlg.com



Printed in USA
 FORM NO.: SS-450ST-100-50M
 PART NO.: 3131812

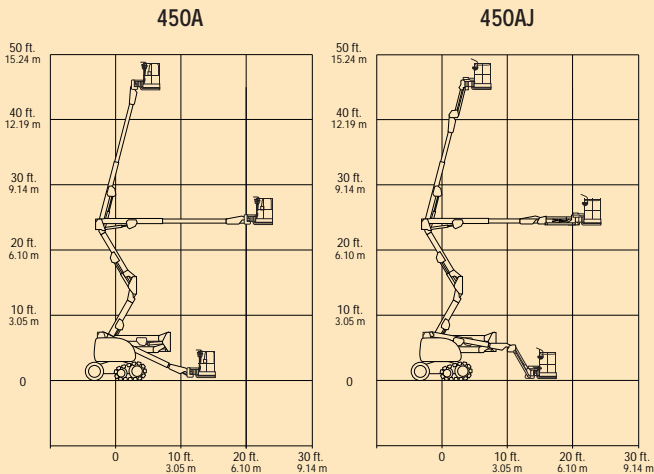

REACH SPECIFICATIONS

Platform Height	45 ft. (13.72 m)
Horizontal Outreach	23 ft. 9 in. (7.24 m)
Up and Over Height	24 ft. 3 in. (7.39 m)
Swing	360 degrees non-continuous
Platform Capacity—Unrestricted	500 lbs. (230 kg)
Platform Rotator	180 degrees hydraulic

450A

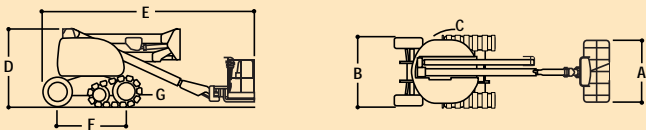

450AJ

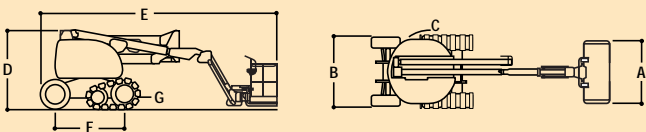

DIMENSIONAL DATA

A. Platform Size	30 in. x 72 in. (0.76 m x 1.83 m)
B. Overall Width	6 ft. 6 in. (1.98 m)
C. Tailswing (working condition)	Zero
D. Stowed Height	7 ft. 4 in. (2.24 m)
E. Stowed Length	20 ft. 2 in. (6.15 m)
F. Wheelbase	6 ft. 6 in. (1.98 m)
G. Ground Clearance	11 in. (28 cm)
Gross Vehicle Weight*	15,600 lbs. (7,078 kg)
Max. Ground Bearing Pressure	46 psi (3.23 kg/cm ²)

CHASSIS

Drive Speed	4.5 mph (7.2 km/h)
Gradeability	30%
Turning Radius (Inside/Outside)	5 ft. 8 in./14 ft. (1.73 m/4.27 m)
Axle Oscillation	8 in. (20 cm)
Tires	Pneumatic, 12 x 16.5
Type of Tracks	Open Bar Steel Track
Tracks Width	14.7 in. (37 cm)

POWER SOURCE

Dual Fuel Engine, Ford LRG-425	70 hp (52 kW)
Diesel Engine, Deutz F3M1011	47 hp (35 kW)
Fuel Tank Capacity	16.5 gal. (62.5 L)
Hydraulic Reservoir	30 gal. (113.6 L)
Auxiliary Power	12V DC

*Certain options or country standards will increase weight.